

**GOODWE**



**ENERGITEKNIK**



# User Manual

## Rechargeable Li-ion Battery System

Lynx Home F Series | Lynx Home F Plus+ Series

V1.7-2023-02-15

**Copyright ©GoodWe Technologies Co., Ltd., 2023. All rights reserved**

No part of this manual can be reproduced or transmitted to the public platform in any form or by any means without the prior written authorization of GoodWe Technologies Co., Ltd.

**Trademarks**

**GOODWE** and other GOODWE trademarks are trademarks of GoodWe Technologies Co.,Ltd. All other trademarks or registered trademarks mentioned in this manual are owned by GoodWe Technologies Co.,Ltd.

**NOTICE**

The information in this user manual is subject to change due to product updates or other reasons. This guide cannot replace the product labels or the safety precautions in the user manual unless otherwise specified. All descriptions here are for guidance only.

# Content

- 1 About This Manual ..... 01**
  - 1.1 Applicable Model..... 01
  - 1.2 Target Audience ..... 01
  - 1.3 Symbol Definition..... 01
  - 1.4 Updates ..... 02
- 2 Safety Precaution ..... 03**
  - 2.1 General Safety ..... 03
  - 2.2 Battery Safety ..... 04
  - 2.3 Emergency Measures ..... 06
  - 2.4 EU Declaration of Conformity..... 06
- 3 Product Introduction ..... 07**
  - 3.1 Product Overview..... 07
  - 3.2 Application Scenarios ..... 08
  - 3.3 Appearance..... 09
  - 3.4 Dimensions ..... 11
- 4 Check and Storage ..... 12**
  - 4.1 Check Before Receiving..... 12
  - 4.2 Deliverables ..... 12
  - 4.3 Storage ..... 13
- 5 System Installation ..... 14**
  - 5.1 Installation Requirements..... 14
  - 5.2 Installing the Battery System ..... 16
    - 5.2.1 Moving the Equipment ..... 16
    - 5.2.2 Installing the Battery System..... 16
    - 5.2.3 Installing the Power Control Unit ..... 19
- 6 Electrical Connection ..... 21**
  - 6.1 Safety Precaution ..... 21
  - 6.2 Electrical Connection ..... 22
  - 6.3 Connecting the PE cable..... 23
  - 6.4 Connecting the Power Cable ..... 24
  - 6.5 Connecting the Communication Cable ..... 28
  - 6.6 Connecting the Terminal Resistor..... 31
  - 6.7 Installing the Protection Cover..... 34
- 7 System Operation ..... 34**

- 7.1 Check Before Power ON ..... 34
- 7.2 Power ON the Battery System ..... 35
- 7.3 Setting the Battery Parameters..... 36
- 7.4 Indicator Status ..... 37
  - 7.4.1 Normal Status ..... 37
  - 7.4.2 Alarming Status ..... 38
  - 7.4.3 Faulty Status ..... 39
- 8 Maintenance ..... 41**
- 8.1 Power OFF the Battery System ..... 41
- 8.2 Routine Maintenance ..... 41
- 9 Parameters ..... 42**

# 1 About This Manual

This manual describes the product information, installation, electrical connection, commissioning, troubleshooting and maintenance. Read through this manual before installing and operating the product. All the installers and users have to be familiar with the product features, functions, and safety precautions. This manual is subject to update without notice. For more product details and latest documents, visit <https://en.goodwe.com>.

## 1.1 Applicable Model

This manual applies to the listed models below:



- LX F6.6-H
- LX F9.8-H
- LX F13.1-H
- LX F16.4-H

## 1.2 Target Audience

This manual applies to trained and knowledgeable technical professionals. The technical personnel has to be familiar with the product, local standards, and electric systems.

## 1.3 Symbol Definition

Different levels of warning messages in this manual are defined as follows:

 <b>DANGER</b>
Indicates a high-level hazard that, if not avoided, will result in death or serious injury.
 <b>WARNING</b>
Indicates a medium-level hazard that, if not avoided, could result in death or serious injury.
 <b>CAUTION</b>
Indicates a low-level hazard that, if not avoided, could result in minor or moderate injury.
<b>NOTICE</b>
Highlights and supplements the texts. Or some skills and methods to solve product-related problems to save time.

## 1.4 Updates

The latest document contains all the updates made in earlier issues.

### V1.0 2022-07-20

- First Issue

### V1.1 2021-12-20

- Updates **5.3** Installing the Battery System

### V1.2 2022-02-18

- Updates **2.2** Symbol Description
- Updates **4.2** Packing List
- Updates **5.4** Electrical Connection
- Updates **6.4** Indicator Status
- Updates **07** Technical Parameters

### V1.3 2022-08-20

- Updates Battery Cluster Application Scenarios.

### V1.4 2022-10-20

- Updates **3.1** Product Overview.

### V1.5 2022-11-20

- Updates **7.2** Power ON the Battery System.

### V1.6 2022-12-15

- Updates **3.4** Dimensions.
- Updates **4.2** Deliverables.
- Updates **5.2** Installing the Battery System.
- Updates **6** Electrical Connection.

### V1.7 2023-02-15

- Updates **4.3** Storage.

## 2 Safety Precaution

Please strictly follow these safety instructions in the user manual during the operation.

### NOTICE

The products are designed and tested strictly to comply with related safety rules. Read and follow all the safety instructions and cautions before any operations. Improper operation might cause personal injury or property damage as the products are electrical equipment.

### 2.1 General Safety

#### NOTICE

- The information in this user manual is subject to change due to product updates or other reasons. This guide cannot replace the product labels or the safety precautions in the user manual unless otherwise specified. All descriptions here are for guidance only.
- Before installations, read through the user manual to learn about the product and the precautions.
- All operations should be performed by trained and knowledgeable technicians who are familiar with local standards and safety regulations.
- Use insulating tools and wear personal protective equipment (PPE) when operating the equipment to ensure personal safety. Wear anti-static gloves, cloths, and wrist strips when touching electronic devices to protect the equipment from damage.
- Strictly follow the installation, operation, and configuration instructions in this manual. The manufacturer shall not be liable for equipment damage or personal injury if you do not follow the instructions. For more warrant information, please visit: <https://en.goodwe.com/warranty>.

## 2.2 Battery Safety















### DANGER

- The battery system exists high voltage during the equipment running. Please keep Power Off before any operations to avoid danger. Strictly follow all safety precautions outlined in this manual and safety labels on the equipment during the operation.
- The inverter used with the battery shall be approved by the battery manufacturer. The approved list of battery and the matched inverter can be obtained through the official website.
- Do not disassemble, modify, or replace any part of the battery or the power control unit without official authorization from the manufacturer. Otherwise, it will cause electrical shock or damages to the equipment, which shall not be borne by the manufacturer.
- Do not hit, pull, drag, squeeze or step on the equipment or put the battery into fire. Otherwise, the battery may explode.
- Do not place the battery in a high temperature environment. Make sure that there is no direct sunlight and no heat source near the battery. When the ambient temperature exceeds 60 °C, it will cause fire.
- Do not use the battery or the power control unit if it is defective, broken, or damaged. Damaged battery may leak electrolyte.
- To protect the battery pack and its components from damage during transportation, please ensure that the transportation personnel are professionally trained. All operations during the transportation have to be recorded. The equipment shall be kept in balance, thus avoiding falling down.
- The battery equipment is heavy. Please equip the corresponding personnel according to its weight, so that the equipment does not exceed the weight range of the human body can carry, and cause personnel injury.
- Contact after-sale service immediately if the battery is not able to be started. Otherwise, the battery might be damaged permanently.
- Do not move the battery system if it is connected with external battery modules. Contact after-sales service if the battery shall be replaced or added.

### CAUTION

- Protect the battery system from damage during transportation and storage.
- The transportation must be carried out by trained professionals. All operations during the process have to be recorded.
- Keep the equipment stable to avoid dumping, which can result in equipment damage and personal injuries.
- Place the cables at least 30mm away from the heating components or heat sources, otherwise the insulation layer of the cables may be aging or broken due to high temperature.
- Tie the cables of the same type together, and place cables of different types at least 30mm apart. Do not place the cables entangled or crossed.

## Label Description

	Potential risks exist. Wear proper personnel protective equipment before any operations.		Install the equipment away from fire sources.
	HIGH VOLTAGE HAZARD. High voltage exists during the equipment's running. Ensure the equipment is power off before any operations.		Keep the equipment away from children.
	Operate the equipment properly to avoid explosion danger.		No extinguishing with water.
	The equipment contains corrosive electrolytes. In case of a leak in the equipment, avoid contact the leaked liquid or gas.		Do not dispose of the equipment with household garbage at its end of life. Dispose it according to local laws and regulations or send it to the manufacturer.
	Batteries contain flammable materials, beware of fire.		Recycle regeneration mark.
	Read through the user manual before any operations.		CE certification mark
	Pay attention to wear PPE during installation, operation and maintaining of the equipment.		Grounding point.

## 2.3 Emergency Measures

### Battery Electrolyte Leakage

---

If the battery module leaks electrolyte, avoid contact with the leaking liquid or gas. The electrolyte is corrosive. It will cause skin irritation or chemical burn to the operator. Anyone contact the leaked substance accidentally has to do as following:

- **Breath in the leaked substance:** Evacuate from the polluted area, and seek immediate medical assistance.
- **Eye contact:** Rinse your eyes for at least 15 minutes with clean water and seek immediate medical assistance.
- **Skin contact:** Thoroughly wash the touch area with soap and clean water, and seek immediate medical assistance.
- **Ingestion:** Induce vomiting, and seek immediate medical assistance.

### Fire

---

- The battery may explode when the ambient temperature exceeds 150°C. Poisonous and hazard gas may be released if the battery is on fire.
- In the event of a fire, please make sure that the carbon dioxide extinguisher or Novac1230 or FM-200 is nearby.
- The fire cannot be put out by water or ABC dry powder extinguisher. Firefighters are required to wear full protective clothing and self-contained breathing apparatus.

## 2.4 EU Declaration of Conformity

GoodWe Technologies Co., Ltd. hereby declares that the inverter without wireless communication modules sold in the European market meets the requirements of the following directives:

- Electromagnetic compatibility Directive 2014/30/EU (EMC)
- Electrical Apparatus Low Voltage Directive 2014/35/EU (LVD)
- Battery Directive 2006/66/EC and Amending Directive 2013/56/EU
- Waste Electrical and Electronic Equipment 2012/19/EU
- Registration, Evaluation, Authorization and Restriction of Chemicals (EC) No 1907/2006 (REACH)

You can download the EU Declaration of Conformity on the official website:<https://en.goodwe.com>.

### 3 Product Introduction

#### 3.1 Product Overview

##### Intended usage

The battery system, which consists of a power control unit (PCU for short) and battery modules, can store and release the electric energy according to the requirements of the solar energy storage system. The input and output ports of the energy storage system are high voltage direct current ports.

##### Usable energy description

#### NOTICE

The battery system supports capacity expansion. A maximum of 5 battery modules can be used to extend the usable energy of the battery system. Strictly follow the expansion requirement. For details, please contact the Dealer or Manufacturer. Otherwise, undervoltage, overvoltage or voltage difference might occur to the battery system.

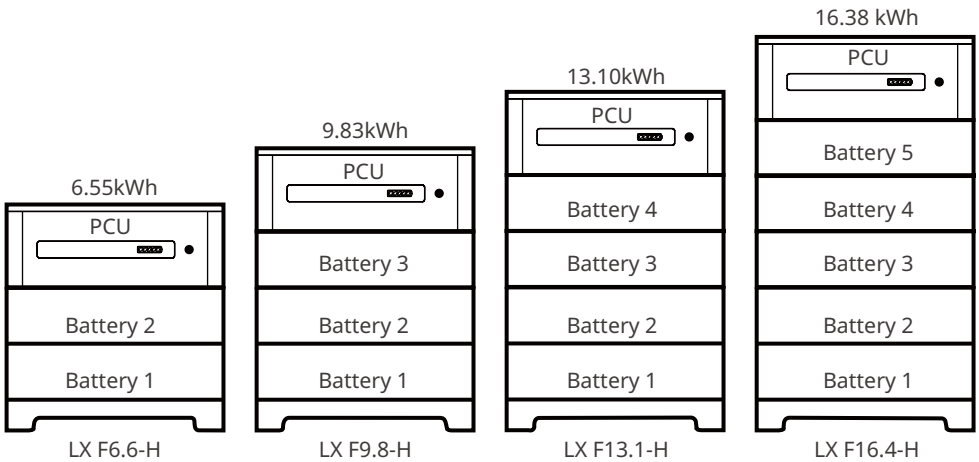

A max of eight battery systems can be parallel connected in one energy storage system. Ensure that the usable energy of each battery system is the same.

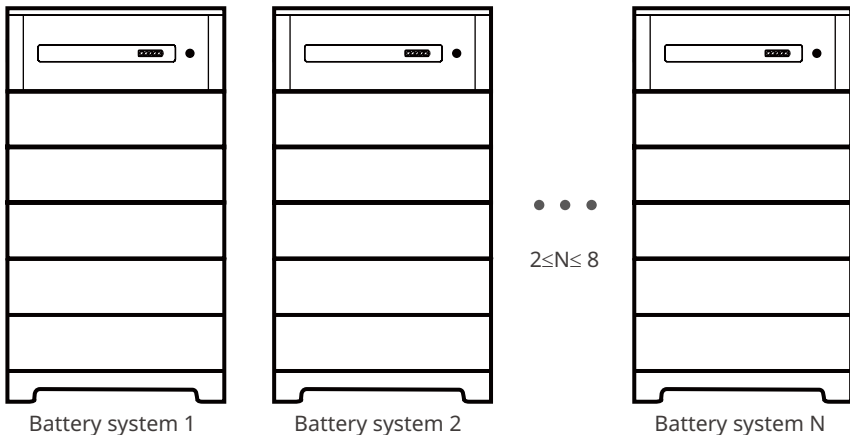

### 3.2 Application Scenarios

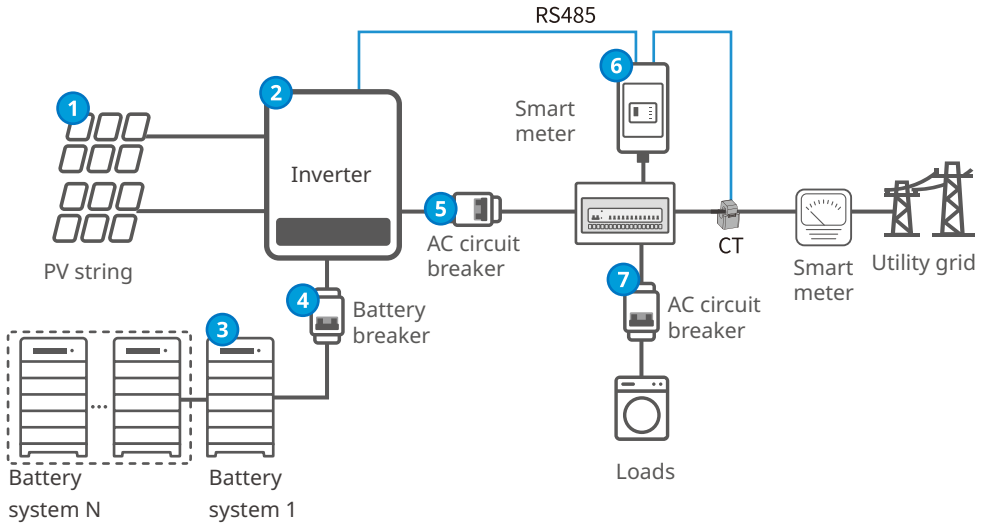

#### Approved inverter list

Scan the QR code below or visit the official website to get the Approved Battery Options Statement.



GoodWe Inverter



GE Inverter

### 3.3 Appearance

#### Battery system appearance

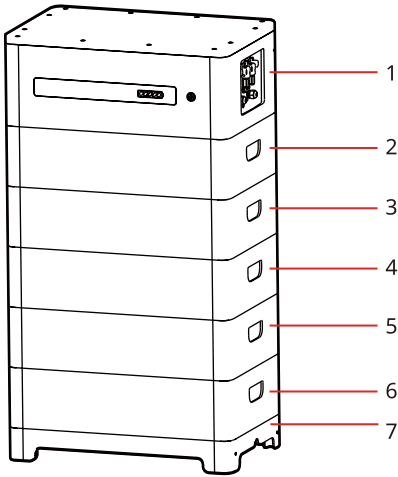

#### NOTICE

- Ensure that the PCU is installed above the battery modules. Do not install any battery modules above the PCU.
- This manual will show you the installation and electrical connection of 5 battery modules.

No.	Parts
1	PCU
2, 3, 4, 5, 6	Battery
7	Base

#### Battery appearance

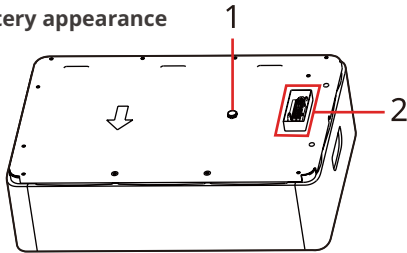

No.	Parts
1	Ventilation valve
2	Rectangular connector

#### Base appearance

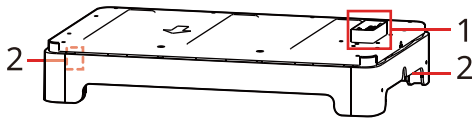

No.	Parts
1	Rectangular connector
2	Grounding point

### Power control unit appearance

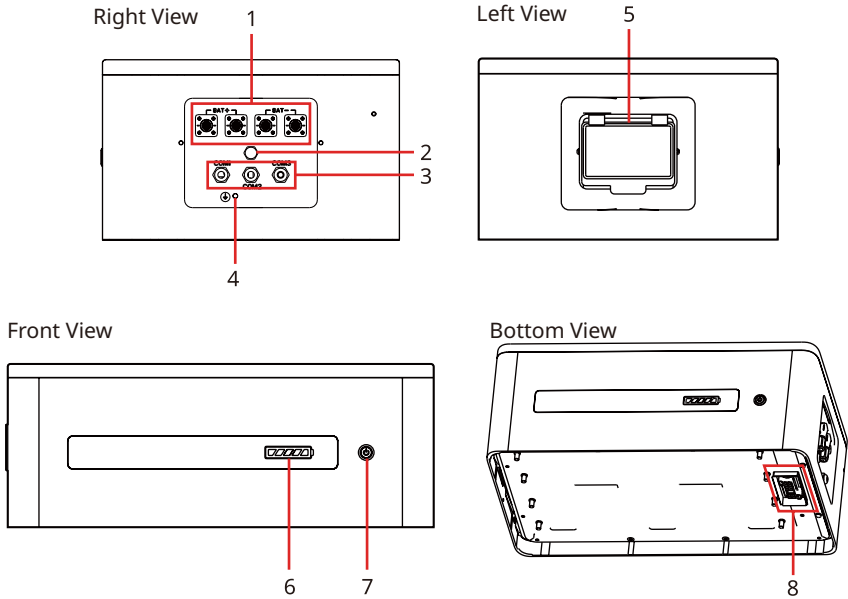

- |  |  |  |
|--|--|--|
| 1. DC terminal (BAT)                             | 2. Ventilation valve                   | 3. Communication terminal (COM) <sup>[1]</sup> |
| 4. Grounding point                               | 5. Air switch                          | 6. SOC indicator                               |
| 7. Multifunction button indicator <sup>[2]</sup> | 8. Battery serial connection interface |  |

[1]. Some models do not have the COM3 terminal, which is designed for battery system parallel connection.

[2]. The multifunction button indicator is designed as an indicator, black start switch, and power off button.

### 3.4 Dimensions

#### Lynx home F series

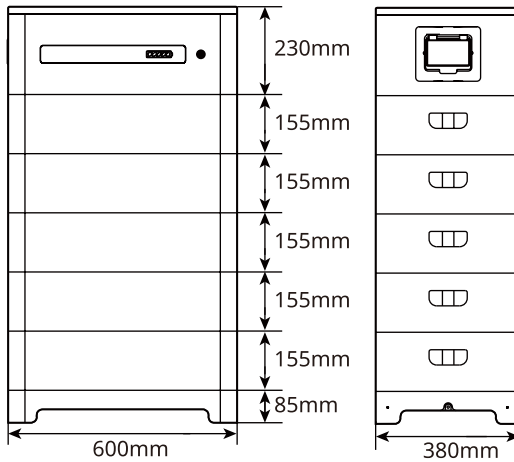

#### Lynx home F Plus+ series

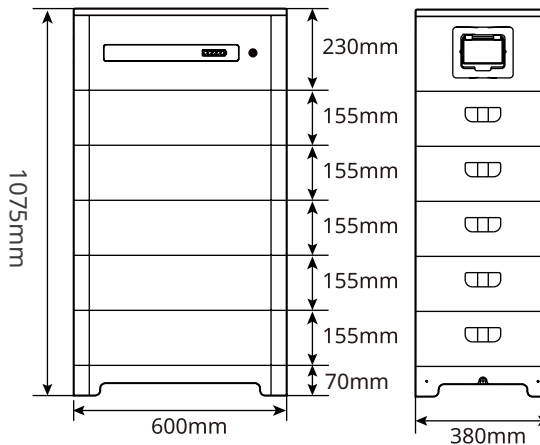

## 4 Check and Storage

### 4.1 Check Before Receiving

Check the following items before receiving the product.

1. Check the outer packing box for damage, such as holes, cracks, deformation, and other signs of equipment damage. Do not unpack the package and contact the supplier as soon as possible if any damage is found.
2. Check the product model. If the product model is not what you requested, do not unpack the product and contact the supplier.
3. Check the deliverables for correct model, complete contents, and intact appearance. Contact the supplier as soon as possible if any damage is found.

### 4.2 Deliverables



#### WARNING

- The adjustable feet are only for Lynx home F Plus+ series.
- The adjustable feet are optional. If you choose to install the battery system using the feet, four pieces of adjustable feet will be provided by default.
- The locking bracket will be different to match the adjustable feet. You can select the locking bracket based on your requirements.
- If you choose to use the adjustable feet, two locking brackets match the feet and two normal locking brackets will be provided by default except for the four adjustable feet.
- If you do not need the adjustable feet, four normal locking brackets will be provided by default.

#### Battery module

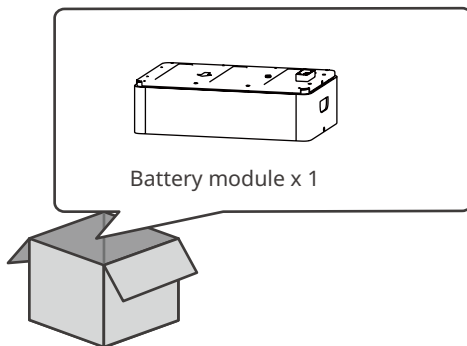

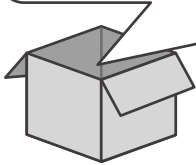
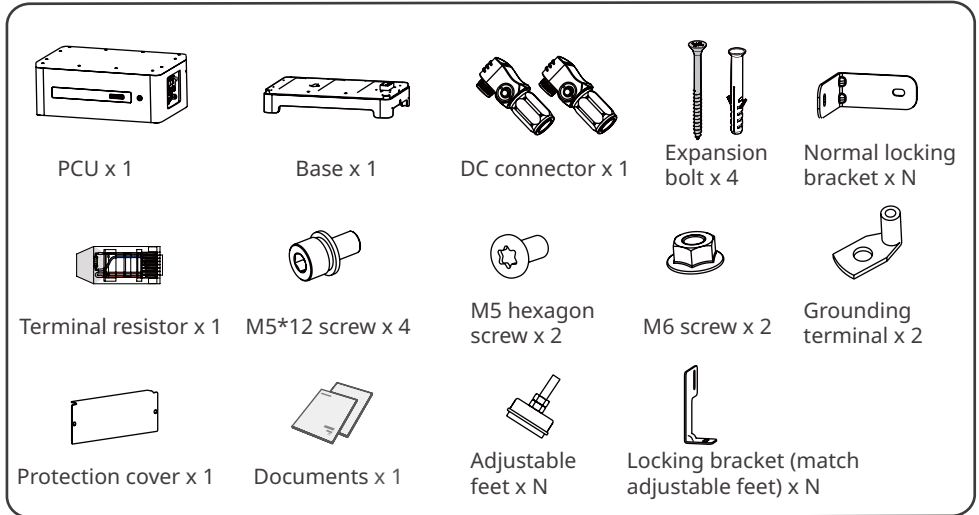
**Power control unit****4.3 Storage**

If the equipment is not to be installed or used immediately, please ensure that the storage environment meets the following requirements:

1. Do not unpack the outer packing box or throw the desiccant away.
2. Complete the equipment installation in three days after unpacking it. Pack and store the equipment using the original packing box if it is not installed.
3. Stack the equipment complying with the labels and requirements on the packing box.
4. The equipment must be stacked with caution to prevent them from falling.
5. Keep the equipment away from flammable, explosive, and corrosive matters.
6. Place the equipment in a cool place where away from direct sunlight.
7. Store the equipment in a clean place. Make sure the temperature and humidity are appropriate and no condensation.
8. Storage SOC: 25%~50% SOC. Circle the charge-discharge every 3 months.
9. Recommended storage temperature: 0°C~35°C (less than one year), -20°C~0°C or 35°C~45°C (less than one month).
10. Recommended storage humidity: 0%~95%RH(no condensation). Do not install the battery if there is any moisture or condensation.

## 5 System Installation

### 5.1 Installation Requirements

#### Installation Environment Requirements

1. Do not install the equipment in a place near flammable, explosive, or corrosive materials.
2. Do not install the equipment in a place that is easy to touch, especially within children's reach. High temperature exists when the equipment is working. Do not touch the surface to avoid burning.
3. Avoid the water pipes and cables buried in the wall when drilling holes.
4. Install the equipment in a sheltered place to avoid direct sunlight, rain, and snow. Build a sunshade if it is needed.
5. Install the equipment in a well-ventilated place to ensure good dissipation. Also, the installation space should be large enough for operations.
6. The equipment with a high ingress protection rating can be installed indoors or outdoors. The temperature and humidity at the installation site should be within the appropriate range.
7. Install the equipment at a height that is convenient for operation and maintenance, electrical connections, and checking indicators and labels.
8. The altitude to install the equipment shall be lower than the maximum working altitude 2000m.
9. Install the equipment away from electromagnetic interference. If there is any radio or wireless communication device below 30MHz near the equipment, make sure that the equipment is at least 30m far away from the wireless device.

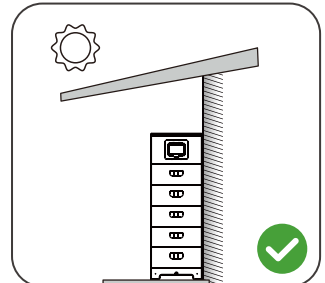
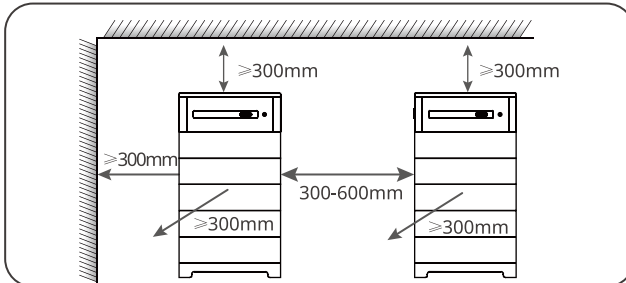
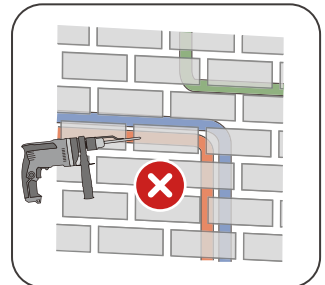

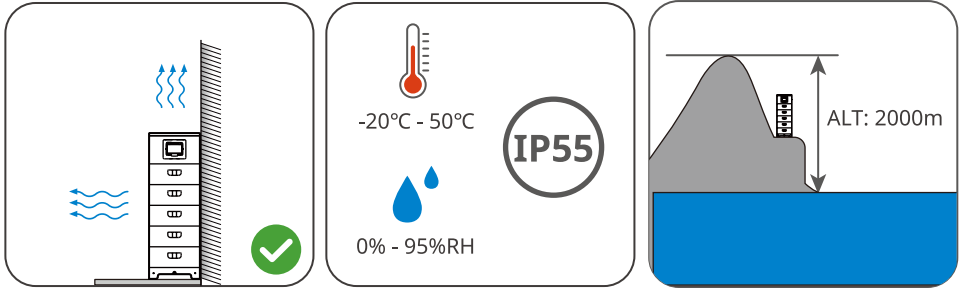

### Mounting Support Requirements

- The mounting support shall be nonflammable and fireproof.
- Install the equipment on a surface that is solid enough to bear the product weight.
- Put the battery system near the wall and install the locking brackets to prevent the battery from falling down.

### Installation Angle Requirements

- Install the equipment vertically, no tilt or upside down.

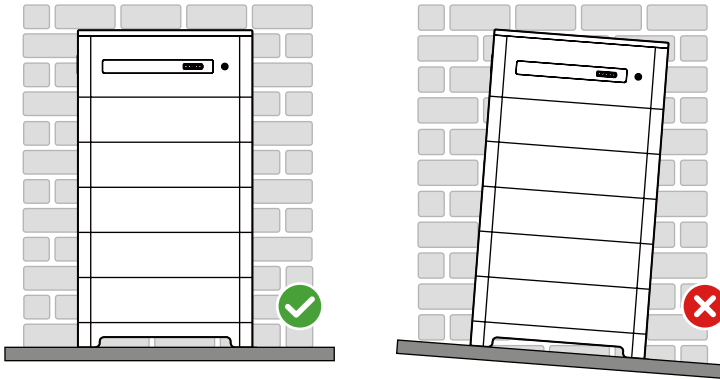

## 5.2 Installing the Battery System

### 5.2.1 Moving the Equipment

#### CAUTION

- Operations such as transportation, turnover, installation and so on must meet the requirements of the laws and regulations of the country or region where it is located.
- Move the equipment to the site before installation. Follow the instructions below to avoid personal injury or equipment damage.
  1. Consider the weight of the equipment before moving it. Assign enough personnel to move the equipment to avoid personal injury.
  2. Wear safety gloves to avoid personal injury.
  3. Keep balance to avoid falling down when moving the equipment.

### 5.2.2 Installing the Battery System

#### NOTICE

- Ensure that the base stands on the floor vertically.
- Ensure that the base clings to the wall and the arrow points outward.
- Ensure that all batteries cling to the wall and the arrow points outward.
- Align the holes of the upper and the lower battery modules when placing the upper battery module.
- Ensure that the locking bracket clings to the wall.
- Do not install the two locking brackets on one side.

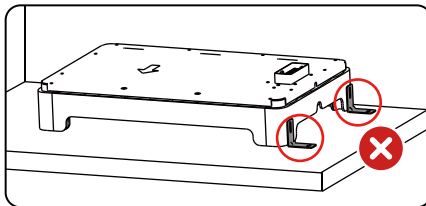
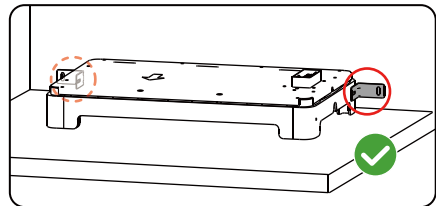
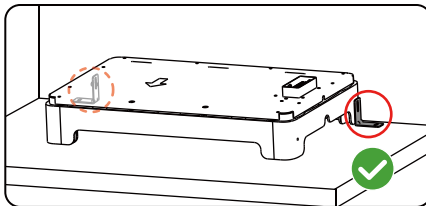

## Installing the Battery System (Without Adjustable Feet)

**Step 1:** Install the locking brackets to the base.

**Step 2:** Place the base cling to the wall and mark the drilling positions. Then remove the base.

**Step 3:** Drill holes using the hammer drill.

**Step 4:** Screw the expansion bolts to fix the base. Ensure that the base is installed in the correct direction.

**Step 5:** Place the battery module on the base, and ensure that the base and the battery are installed in the same direction.

**Step 6:** Install the remaining batteries according to actual battery system type.

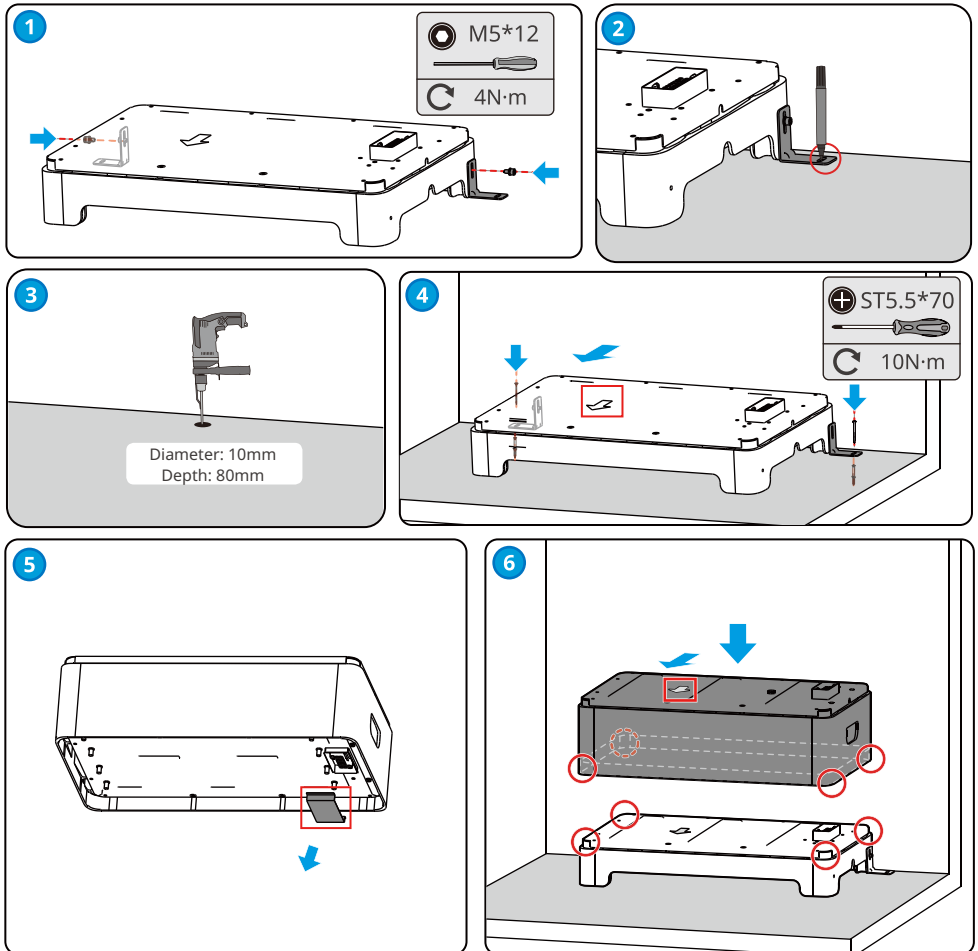

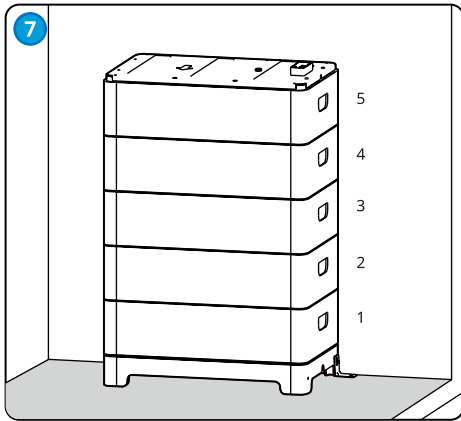

## Installing the Battery System (With Adjustable Feet)

Only for Lynx home F Plus+ series.

**Step 1:** Install the adjustable feet to the base.

**Step 2:** Install the locking brackets to the base.

**Step 3:** Place the base cling to the wall and mark the drilling positions. Then remove the base.

**Step 4:** Drill holes using the hammer drill.

**Step 5:** Screw the expansion bolts to fix the base. Ensure that the base is installed in the correct direction.

**Step 6:** Place the battery module on the base, and ensure that the base and the battery are installed in the same direction.

**Step 7:** Install the remaining batteries according to actual battery system type.

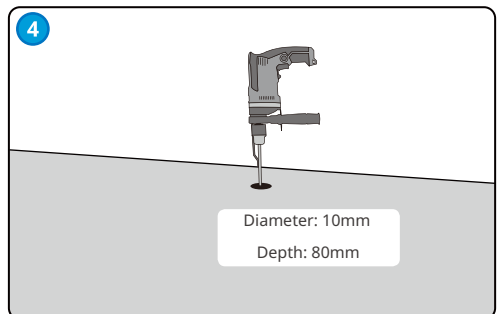
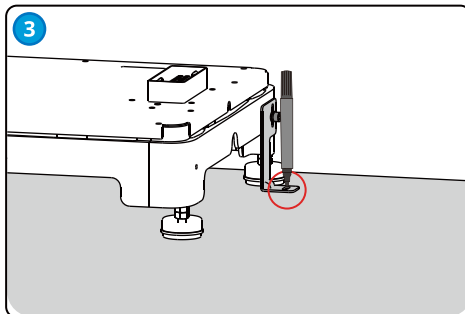
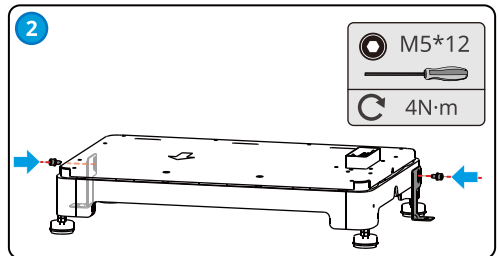
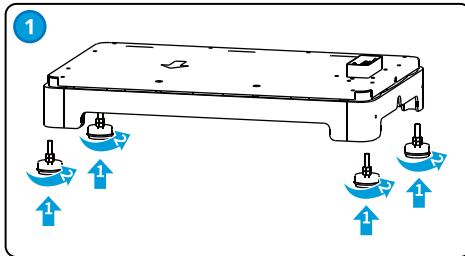

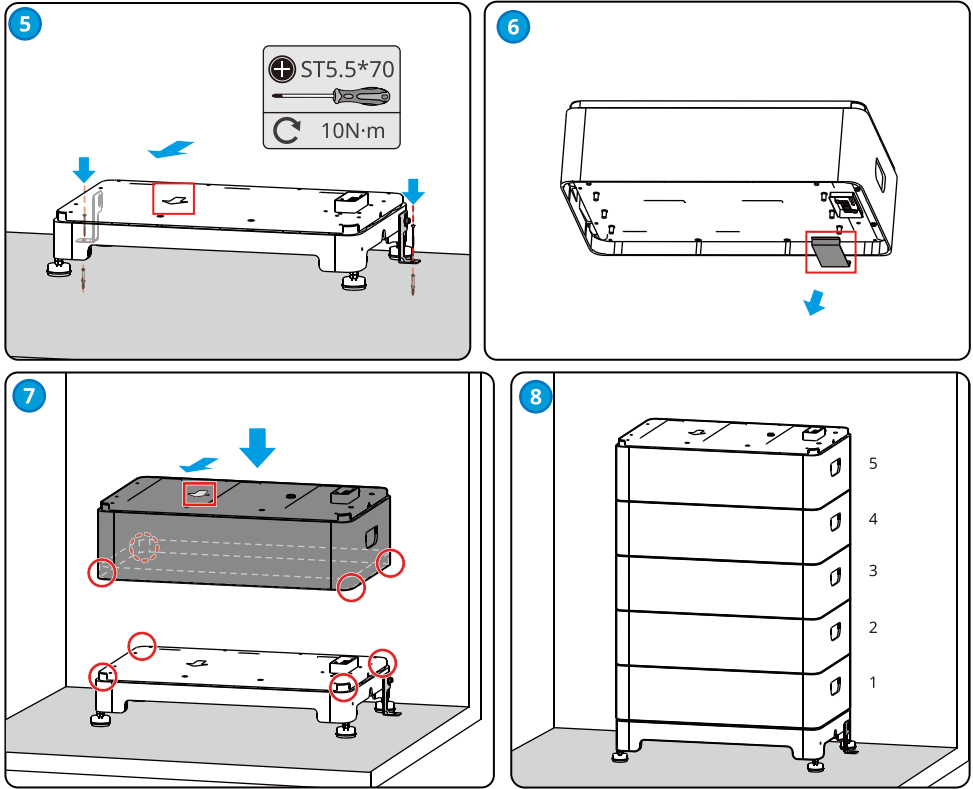

### 5.2.3 Installing the Power Control Unit

#### NOTICE

- Cover the equipment with a cardboard to prevent foreign matters when drilling holes.
- Put the locking bracket of the PCU cling to the wall, and ensure that the bottom of the PCU is vertically and closely put on the battery.

**Step 1:** Install the locking brackets of the PCU.

**Step 2:** Put the PCU above the installed battery modules securely. Mark the drilling hole using a marker, then remove the PCU.

**Step 3:** Drill holes using the hammer drill.

**Step 4:** Secure the locking brackets to prevent the PCU from falling down.

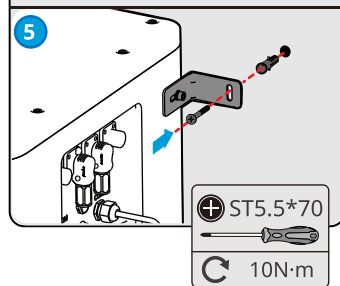
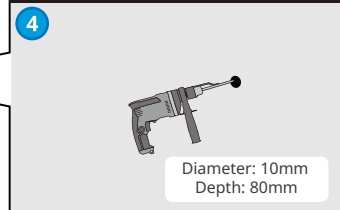
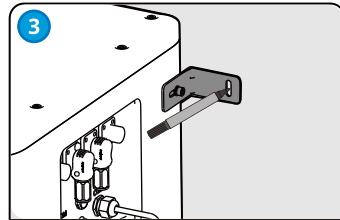
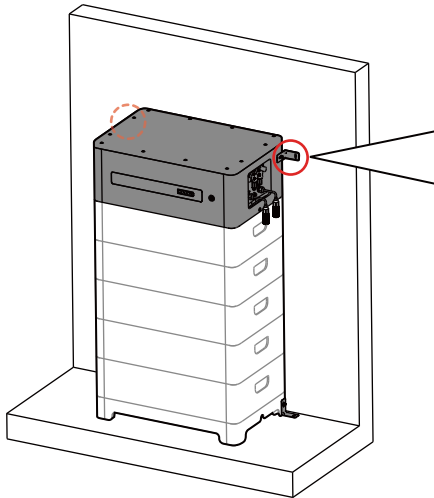
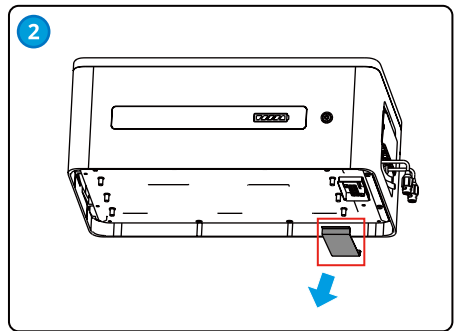
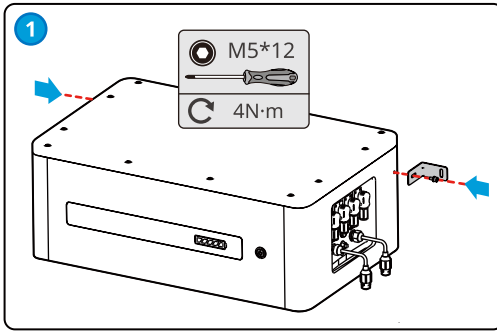

## 6 Electrical Connection

### 6.1 Safety Precaution

 **DANGER**

- The battery system exists high voltage during the equipment running. Please keep Power Off before any operations to avoid danger. Strictly follow all safety precautions outlined in this manual and safety labels on the equipment during the operation.
- All operations, cables and parts specification during the electrical connection shall be in compliance with local laws and regulations.
- Tie the same type cables together, and place them separately from cables of different types. Do not place the cables entangled or crossed.
- Make sure that the cable conductor is in full contact with the terminal and the cable insulation part is not crimped with the terminal when crimping the terminal. Otherwise, the device may not be able to work properly, or the connection may be unreliable during working, which may cause terminal block damage, etc.

**NOTICE**

- Wear personal protective equipment like safety shoes, safety gloves, and insulating gloves during electrical connections.
- All electrical connections should be performed by qualified professionals.
- Cable colors in this document are for reference only. The cable specifications shall meet local laws and regulations.

## Single battery system

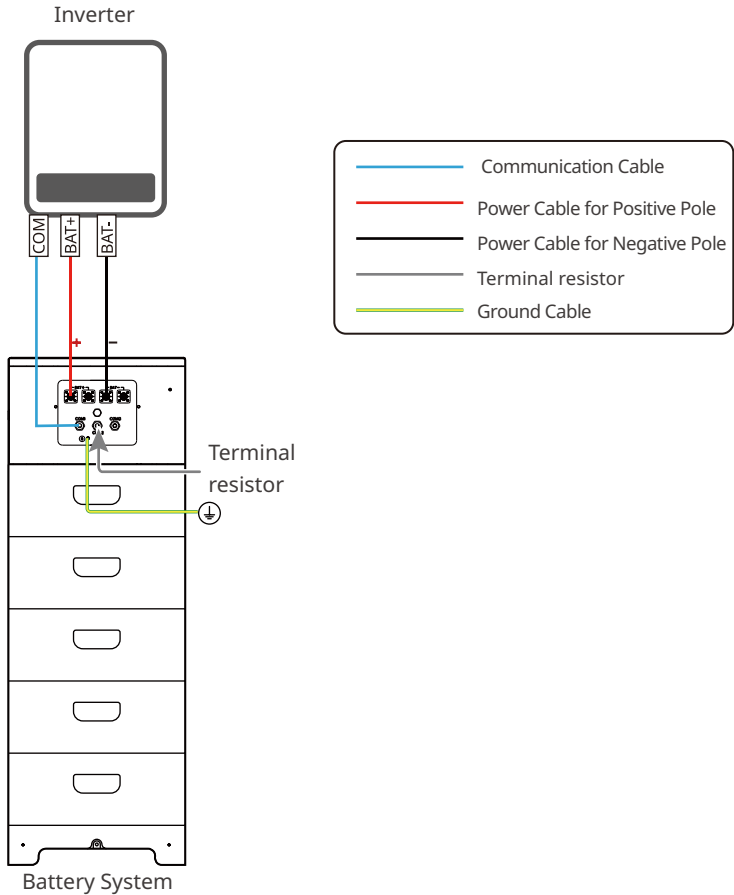

## 6.2 Electrical Connection

### NOTICE

- A max of eight battery systems can be parallel connected in one energy storage system. Ensure that the usable energy of each battery system is the same.
- Install the terminal resistor to the COM3 port of Battery system 1, which is connected to the inverter directly.
- Install the terminal resistor to the COM2 port of Battery system N, which is the last battery system of the battery cluster system.
- The battery cluster interlock function will fail if the terminal resistor is not installed.

## Parallized battery systems

Only for Lynx home F Plus+ series.

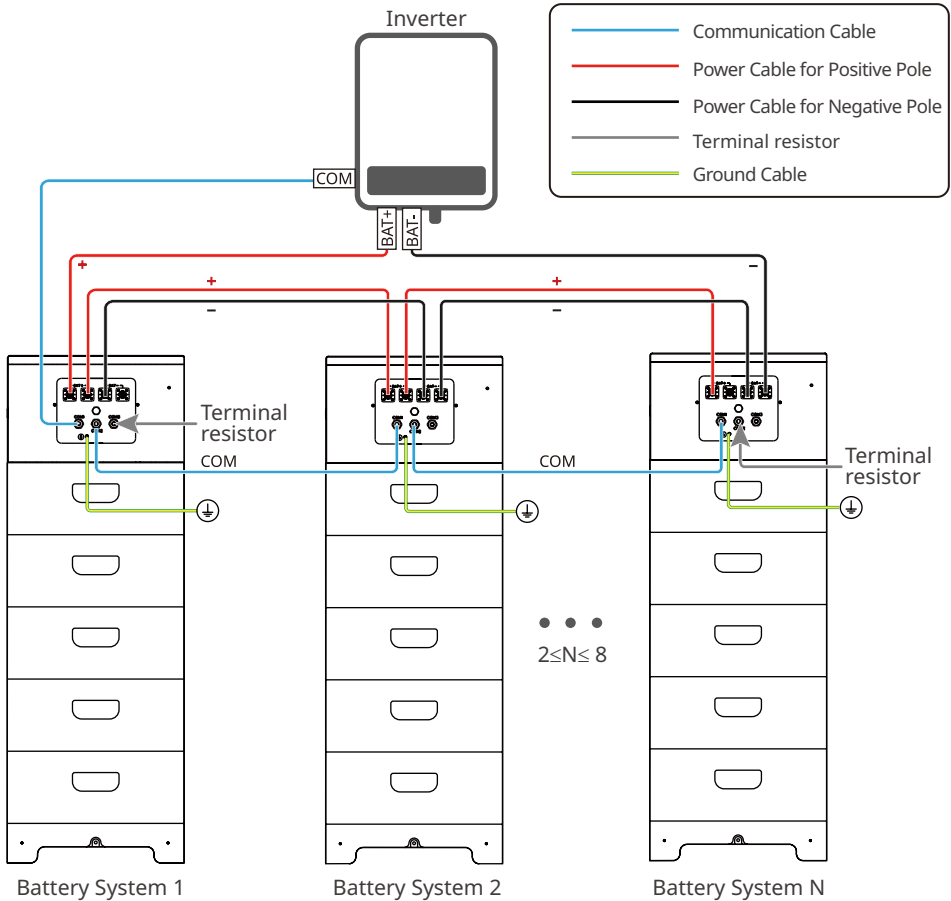

## 6.3 Connecting the PE cable

### NOTICE

- Connect the PE cable first before installing the equipment. Disconnect the PE cable before dismantling the equipment.
- The drawing force of the cable after crimping should be at least 400N.
- Connect the PE cable to the PCU or to the base in the same way.
- The PE cable should be prepared by the customer. Recommended specifications:
  - Type: single-core outdoor copper cable
  - Cross-sectional area: 4-6mm<sup>2</sup>

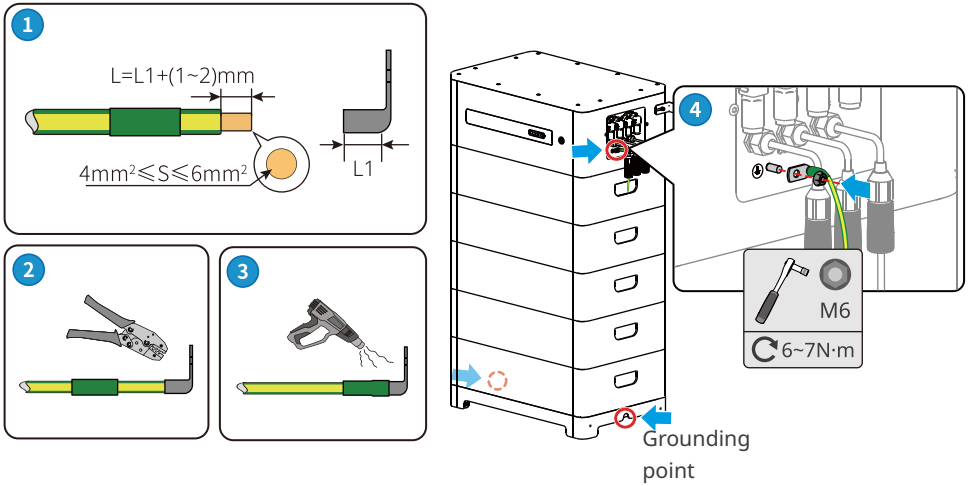

## 6.4 Connecting the Power Cable

### NOTICE

- Power off the battery system before connecting the power cable to avoid high voltage danger.
- The DC input cable should be prepared by customers. Connect the red power connector to the red wire harness. And the black power connector to the black wire harness. The cable should meet standards for outdoor use.
- Install the back cover properly and make sure there is no space.
- The unused ports shall be protected using a cover.

### Connecting the power cable (Type 1)

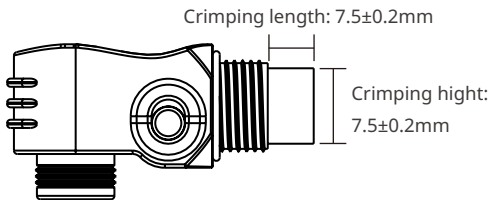

**Cross-sectional area of the power cable S:  $14\text{mm}^2 \leq S \leq 16\text{mm}^2$** **NOTICE**

- Recommended tool: manual hydraulic press plier. Crimping height: 7mm; moulding: 16mm<sup>2</sup>
- The drawing force of the cable after crimping should be at least 1200N.
- The copper tube should be prepared by customers. Copper tube length: 17mm, copper tube inner diameter: 5.80mm.

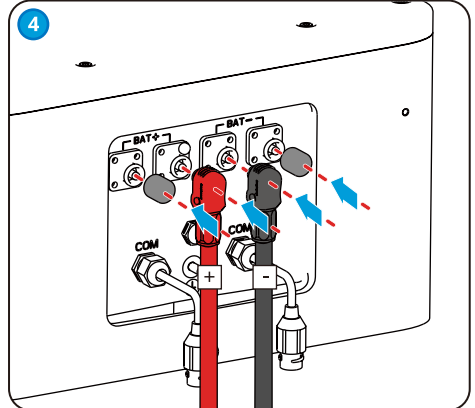
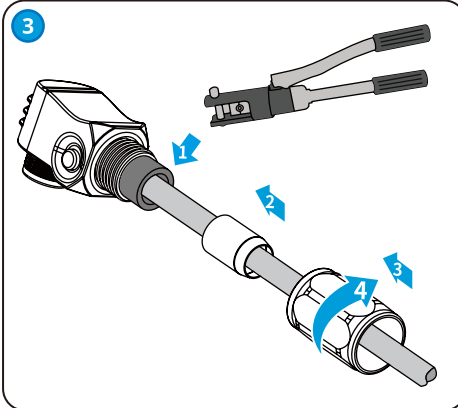
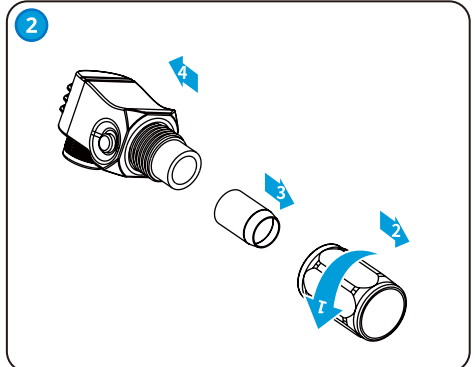
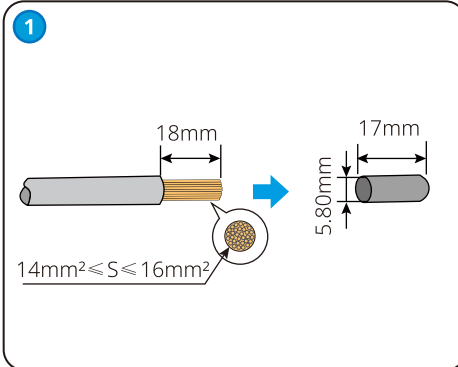

**Cross-sectional area of the power cable S:  $4\text{mm}^2 \leq S \leq 6\text{mm}^2$**

### NOTICE

- Replace the white seal ring inside the power connector with a black seal ring (inner diameter 4.59mm) before crimping the power cable.
- Make sure the conductor cut is flat after folding in half.
- The copper tube should be prepared by customers. Copper tube length: 17mm, copper tube inner diameter: 5.80mm.
- The drawing force of the cable after crimping should be at least 500N.

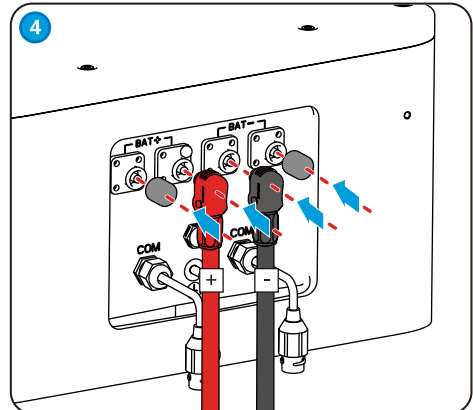
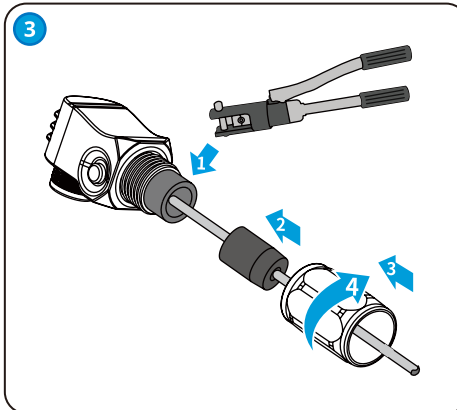
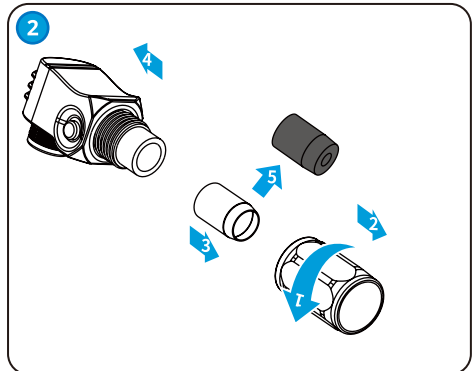
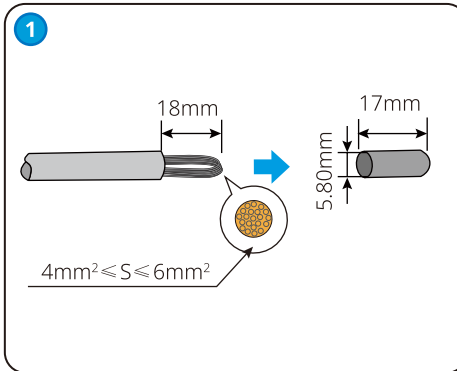

## Connecting the power cable (Type 2)

Only for Lynx home F Plus+ series.

### NOTICE

- The drawing force of the cable after crimping should be at least 1200N when the cross-sectional area range of the cable is  $14\text{mm}^2 \leq S \leq 16\text{mm}^2$ .
- The drawing force of the cable after crimping should be at least 500N when the cross-sectional area range of the cable is  $4\text{mm}^2 \leq S \leq 6\text{mm}^2$ .

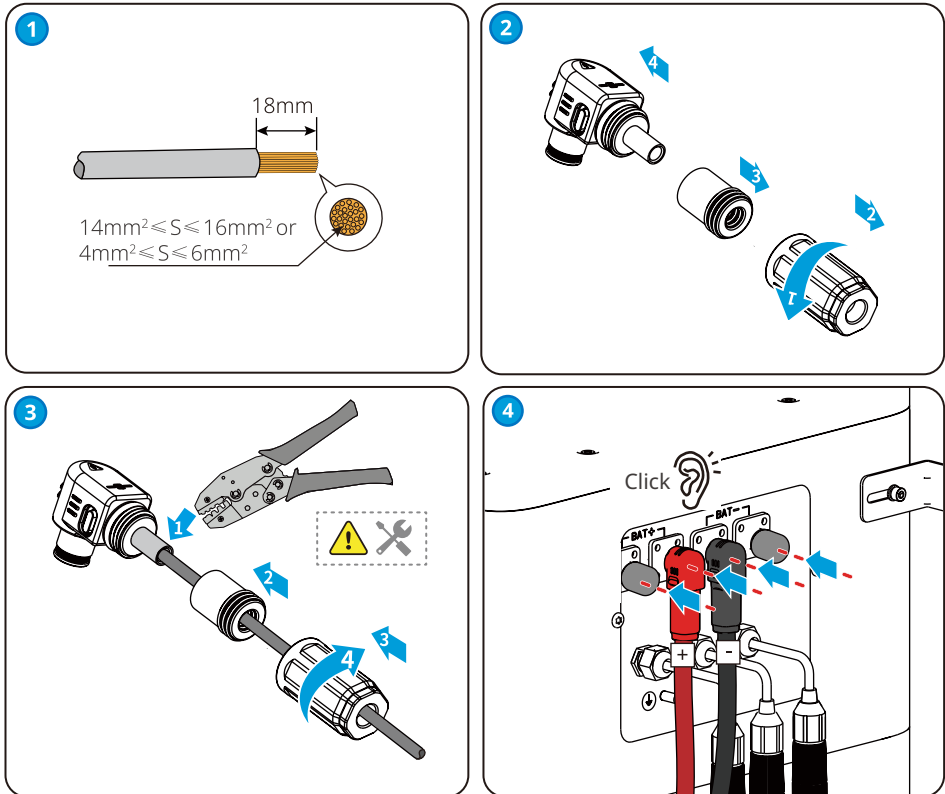

## 6.5 Connecting the Communication Cable

### NOTICE

- The two battery communication ports have the same function.
- Connect the cable to any one of the two communication ports. And connect the terminal resistor to the other port.
- For the EHB series and GE series inverters, the manufacturer does not supply the battery communication cable.
- Please refer to the following pin definitions if you need to make a new battery communication cable.

**Step 1:** Disassemble the waterproof module.

**Step 2:** Run the communication cable through the waterproof module.

**Step 3:** Connect the communication cable to the battery. Tighten the waterproof module.

### Lynx home F series

#### RJ45 Connector

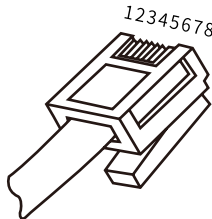

PIN	Description
4	CAN_H
5	CAN_L
1,2,3,6,7,8	N/A

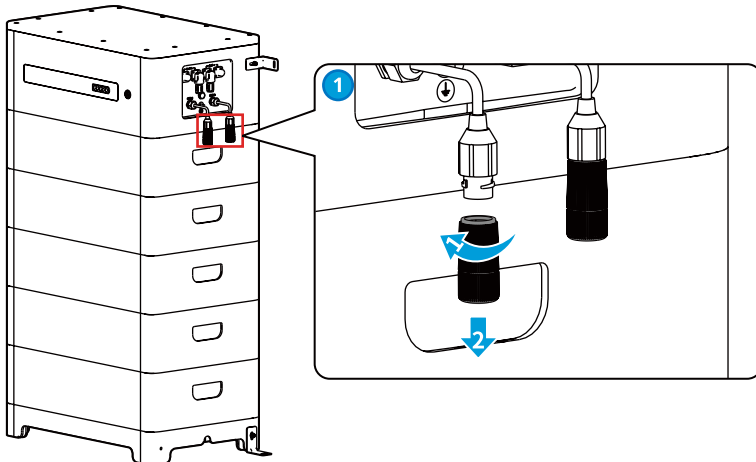

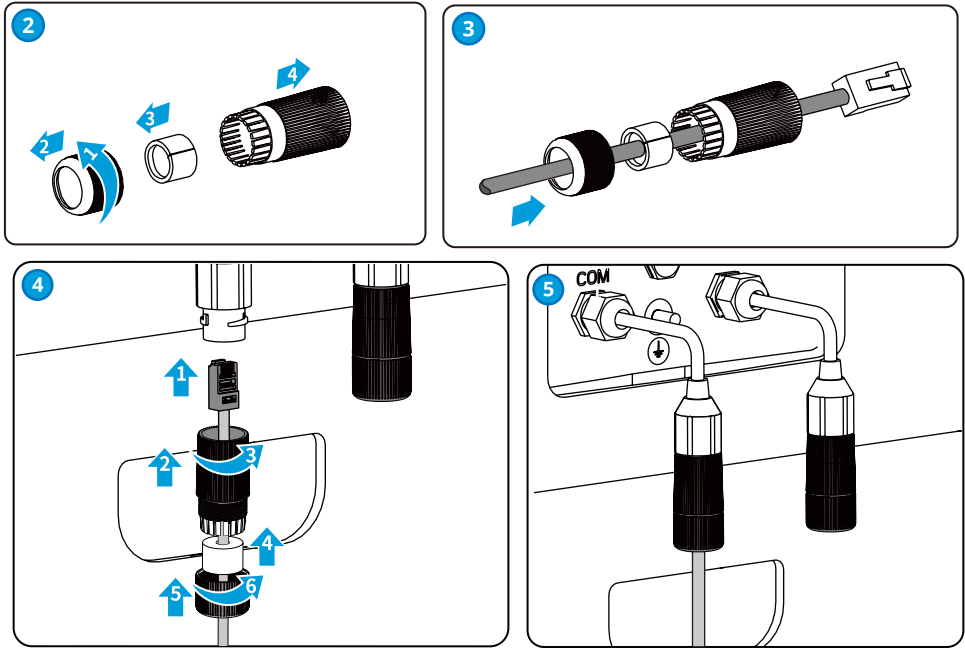

**Lynx home F Plus+ series**  
**RJ45 Connector**

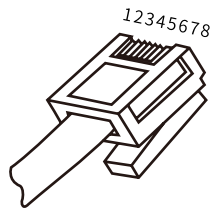

**PIN Definition**

PIN	COM1	COM2	COM3	Description
1	CAN_3H	CAN_3H	CAN_3H	BMS communication for battery system parallel connection
2	CAN_3L	CAN_3L	CAN_3L	
3	N/A	N/A	N/A	Reserved
4	CAN_2H	N/A	N/A	COM1: connects to the inverter BMS communication port to communication with the inverter COM2, COM3: reserved
5	CAN_2L	N/A	N/A	
6	GND	GND	GND	PIN for grounding.
7	HVIL IN	HVIL IN	N/A	COM1, COM2: interlock function COM3: reserved
8	HVIL OUT	HVIL OUT	N/A	

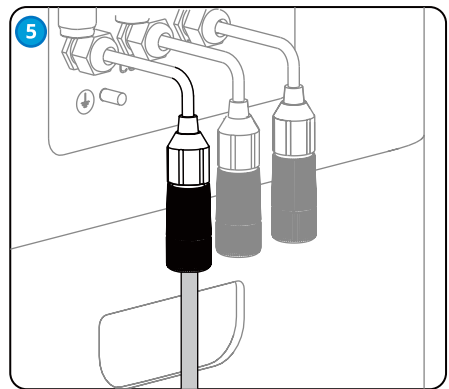
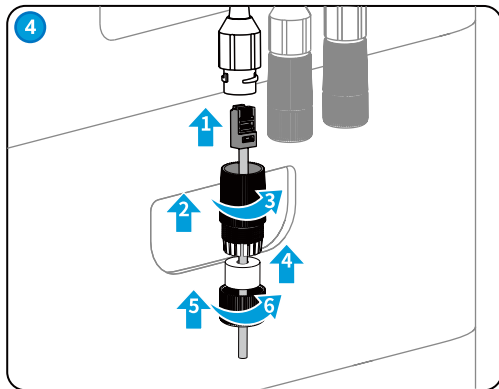
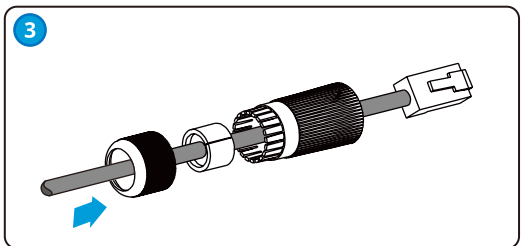
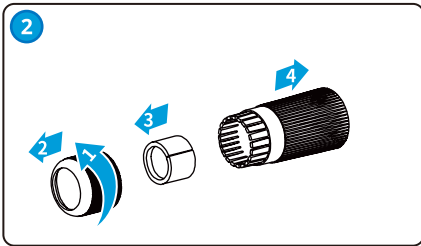
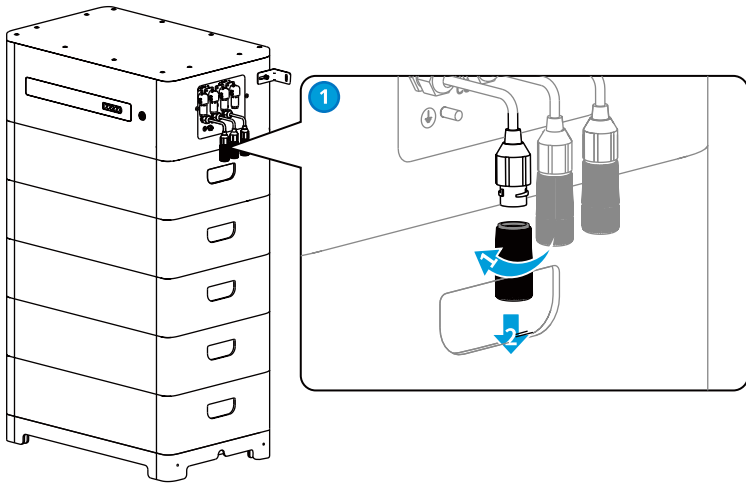

## 6.6 Connecting the Terminal Resistor

### NOTICE

If the terminal resistor is not installed, the Interlock Failure will occur, and the system cannot work correctly.

**Step 1:** Disassemble the waterproof module.

**Step 2:** Install the terminal resistor.

**Step 3:** Tighten the waterproof module.

### Lynx home F series

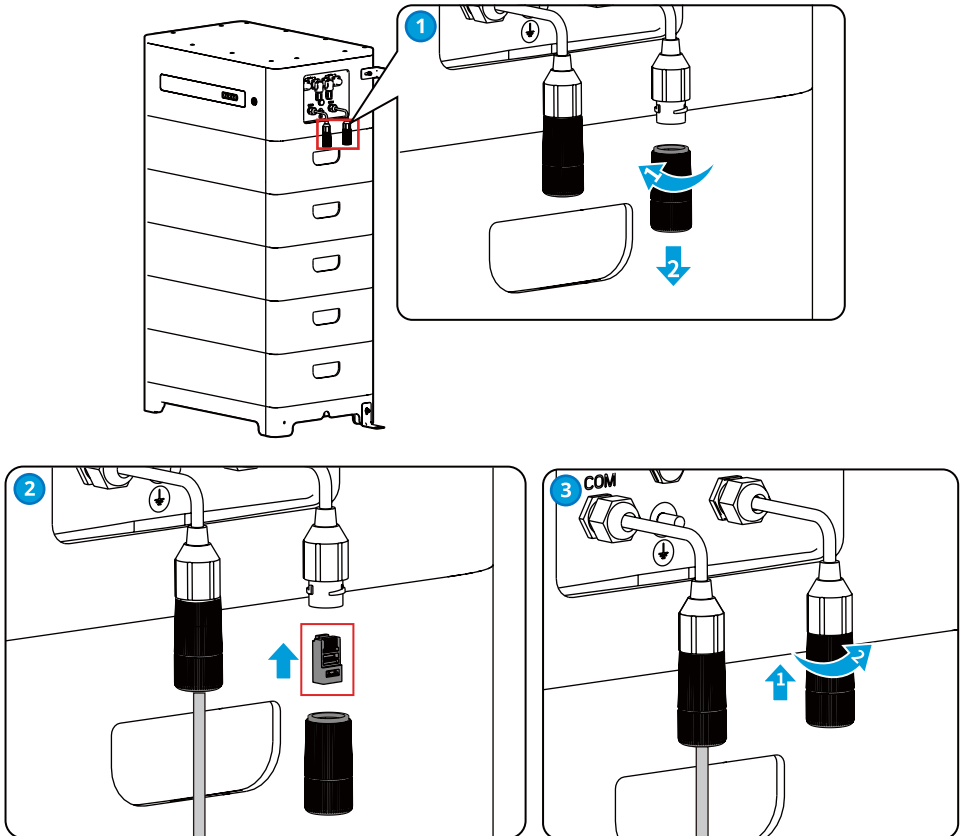

## Lynx home F Plus+ series

### Single battery system

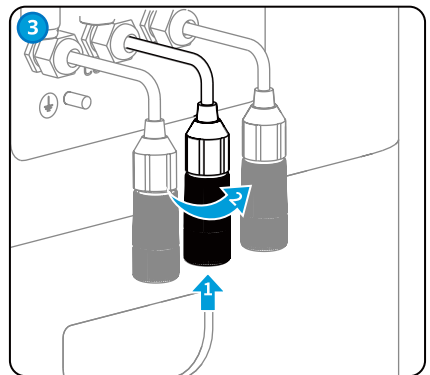
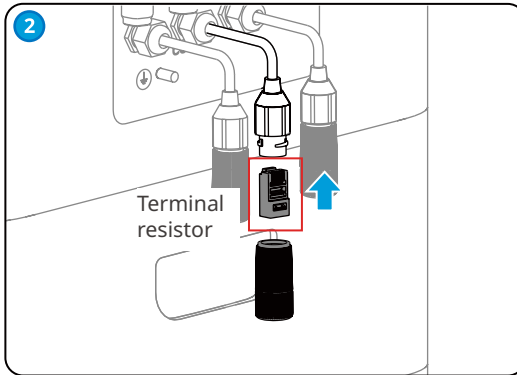
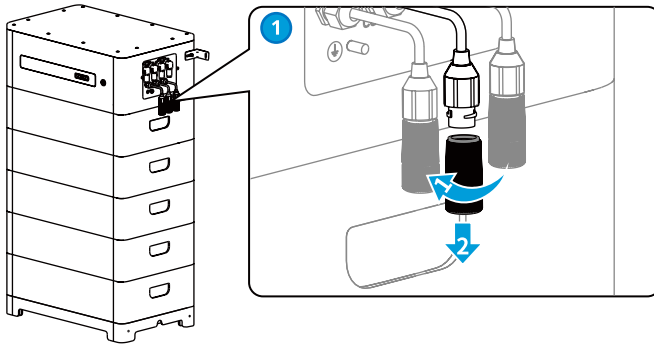

### Parallized battery systems

For Battery 1

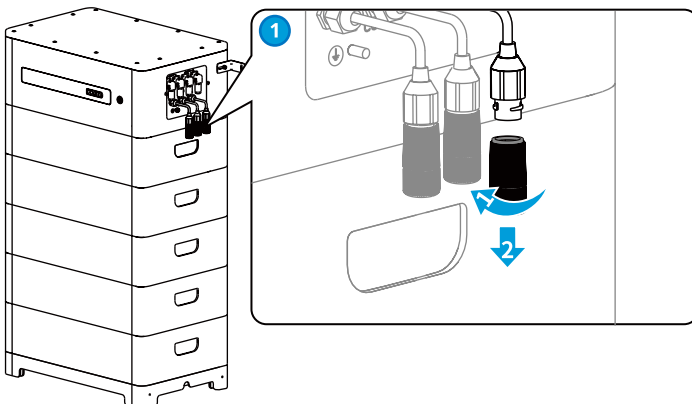

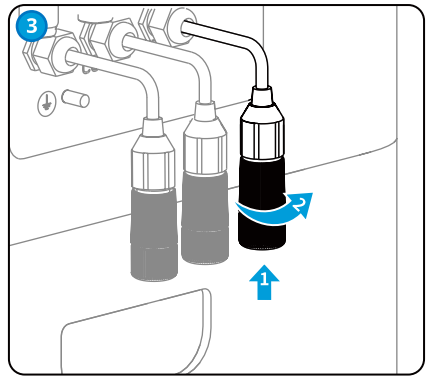
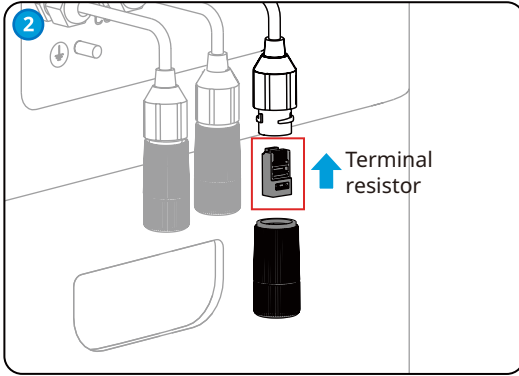

For Battery N

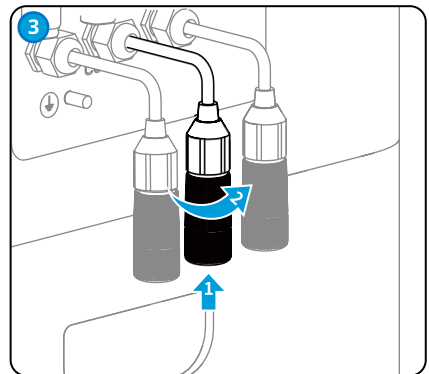
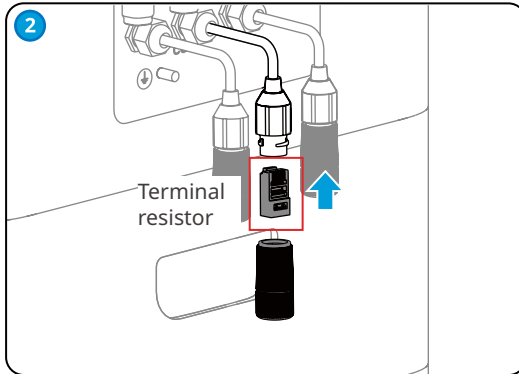
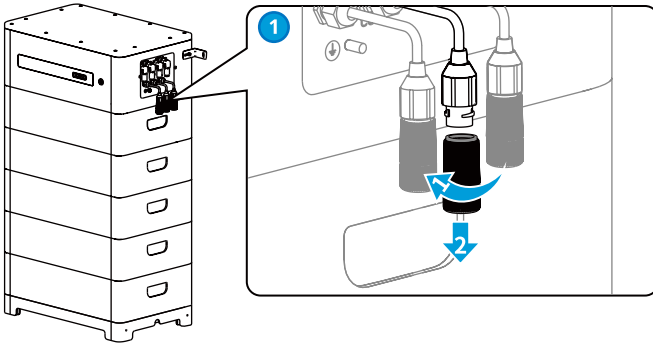

## 6.7 Installing the Protection Cover

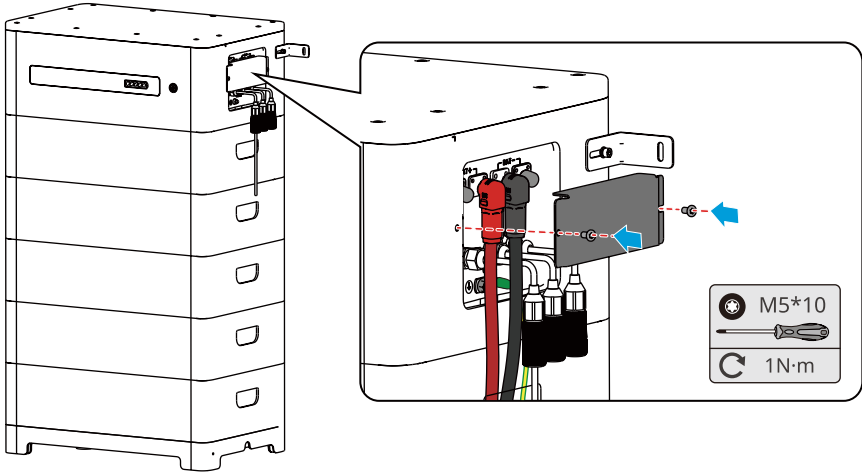

## 7 System Operation

### 7.1 Check Before Power ON

Check the following items before power on to avoid the battery system being damaged.

No.	Check Item
1	The inverter is firmly installed in a clean place where is well-ventilated and easy to operate.
2	The PE cable, power cable, communication cable, and terminal resistor are connected correctly and securely.
3	Cable ties are intact, routed properly and evenly.
4	Unused ports and terminals are sealed.

## 7.2 Power ON the Battery System

### NOTICE

- The DC breaker between the inverter and the battery (DC Breaker 2), and between the two batteries (DC Breaker 5), shall be installed in accordance with local laws and regulations.
- The breaker should isolate both positive and negative conductors simultaneously.

**Step 1:** (Optional) Turn on the breaker between the inverter and the battery system.

**Step 2:** Turn on the air switch of the battery system.

**Step 3:** Turn on the inverter in the system following the instructions in the user manual of the inverter.

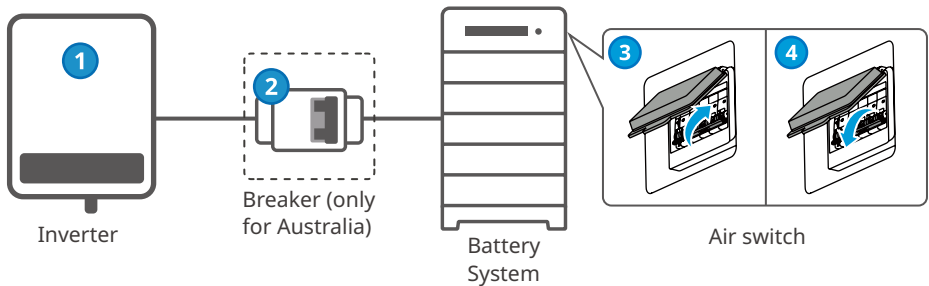

### Parallized battery systems

Only for Lynx home F Plus+ series.

**Step 1:** (Optional) Turn on the breaker between the inverter and the battery system.

**Step 2:** Turn on the breakers between the battery systems.

**Step 3:** Turn on the air switches of the battery systems in turn.

**Step 4:** Turn on the inverter in the system following the instructions in the user manual of the inverter.

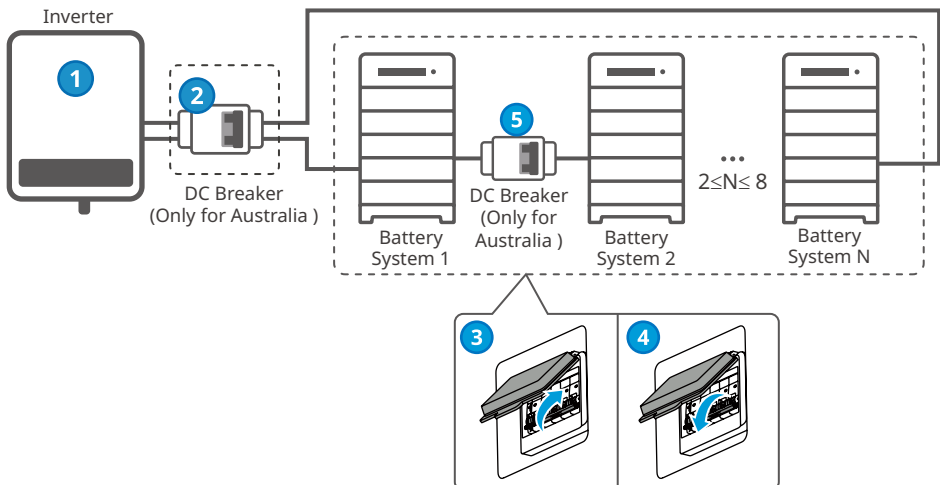

### 7.3 Setting the Battery Parameters

Select battery model via SolarGo after successfully connecting the battery module and the inverter.

App installation and connection

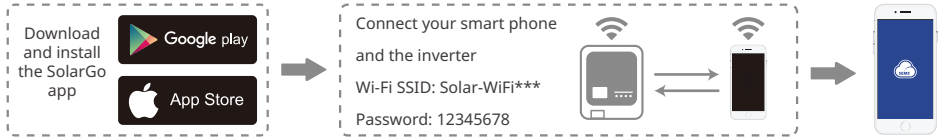

Set battery model via the SolarGo app.

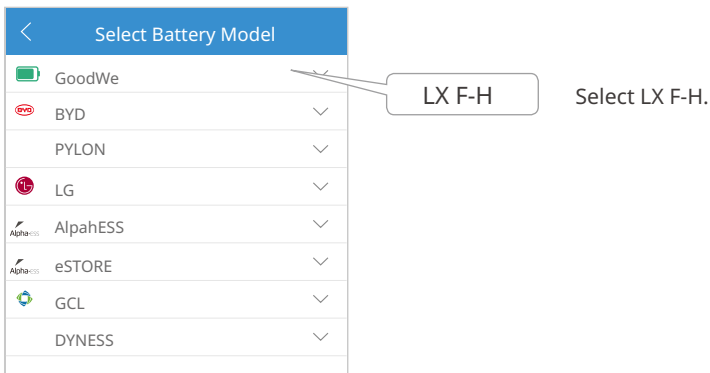

#### NOTICE





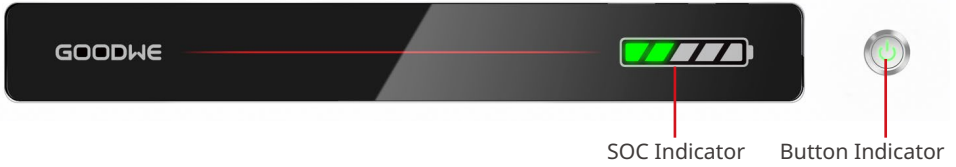

"Battery Communication Failure" will be displayed if you select the wrong battery model. Please select the right battery model accordingly.

## 7.4 Indicator Status











Button Indicator	Status
Green	Standby or Working
Red	Alarming or Faulty

### 7.4.1 Normal Status











Button Indicator	SOC Indicator	Description
Idle: green light double blink Standby: green light single blink Working: steady green		SOC<5%
		5%≤SOC<25%
		25%≤SOC<50%
		50%≤SOC<75%
		75%≤SOC<95%
		SOC≥95%









NOTICE
<ul style="list-style-type: none"> <li>• The SOC indicator keeps on when charging.</li> <li>• The SOC indicator single blinks when discharging.</li> </ul>

### 7.4.2 Alarming Status

Button Indicator	SOC Indicator	Alarm	Solutions
Red light double blink		Battery Overvoltage	Restart the battery. If the problem persists, please contact the after-sales service.
		Battery Undervoltage	Long press the button for 5 seconds to start the battery under charging conditions. If the problem persists, contact the after-sales service.
		Overcurrent Charging	Restart the battery. If the problem persists, please contact the after-sales service.
		Overcurrent Discharging	Restart the battery. If the problem persists, please contact the after-sales service.
		Temperature Difference Exception	Power off and wait for 2 hours. If the problem persists, please contact the after-sales service.
		High Temperature	Power off and wait for 2 hours. If the problem persists, please contact the after-sales service.
		Low Temperature	Power off and wait for 2 hours. If the problem persists, please contact the after-sales service.
		Interlock Failure	Contact the after-sales service.
		Others	Contact the after-sales service.

### 7.4.3 Faulty Status

Button Indicator	SOC Indicator	Fault	Solutions
Steady red		Battery Overvoltage	Restart the battery. If the problem persists, please contact the after-sales service.
		Battery Undervoltage	Long press the button for 5 seconds to start the battery under charging conditions. If the problem persists, contact the after-sales service.
		Overcurrent Charging	Restart the battery. If the problem persists, please contact the after-sales service.
		Overcurrent Discharging	Restart the battery. If the problem persists, please contact the after-sales service.
		Temperature Difference Exception	Power off and wait for 2 hours. If the problem persists, please contact the after-sales service.
		High Temperature	Power off and wait for 2 hours. If the problem persists, please contact the after-sales service.
		Low Temperature	Power off and wait for 2 hours. If the problem persists, please contact the after-sales service.
		Inconsistent Software Version	Contact the after-sales service.
		Precharge Fault	Restart the battery. If the problem persists, please contact the after-sales service.
		Relay Fault	Restart the battery. If the problem persists, please contact the after-sales service.

Steady red		Air Switch Fault	Restart the battery. If the problem persists, please contact the after-sales service.
		Insulation Fault	Do not touch the battery and contact the after-sales service.
		Internal Communication Fault	Power off and check the communication cables. Restart the battery. If the problem persists, contact the after-sales service.
		SN Fault	Contact the after-sales service.
		Voltage Balance Fault	Restart the battery. If the problem persists, please contact the after-sales service.
		Inconsistent Master and Slave	Restart the battery. If the problem persists, please contact the after-sales service.
		Temp. Sensor Fault	Restart the battery. If the problem persists, please contact the after-sales service.
		Others	Contact the after-sales service.

## 8 Maintenance

### 8.1 Power OFF the Battery System

#### DANGER

- Power off the battery system before operations and maintenance. Otherwise, the equipment may be damaged or electric shocks may occur.
- Push the air switch to restart the battery.

Follow the steps below to power off the battery system to prevent the system from being damaged.

#### Method one:

**Step 1:** Turn off the inverter in the system following the instructions in the user manual of the inverter.

**Step 2:** Long press the multifunction button indicator for more than 15s, and make sure that the SOC indicator and multifunction button indicator of the PCU are off.

#### Method two:

**Step 1:** Turn off the inverter in the system following the instructions in the user manual of the inverter.

**Step 2:** Disconnect the air switch, and make sure that the SOC indicator and multifunction button indicator of the PCU are off.

### 8.2 Routine Maintenance

#### WARNING

- Contact after-sales service for help if you find any problems that may influence the battery or the hybrid inverter. Disassemble without permission is strictly forbidden.
- Contact after-sales service for help if the copper conductor is exposed. Do not touch or disassemble privately because the high voltage danger exists.
- In case of other emergencies, contact after-sales service as soon as possible. Operate following the instructions or wait for the after-sales service personnel.

Maintaining Item	Maintaining Period
Check whether the locking brackets are secured, tighten it if not.	Once every 6 months
Check whether the outer enclosure is broken. Repair the painting or contact after-sales service if there is any broken.	Once every 6 months
Check whether there is an exposed cable. Replace the exposed cable or contact the after-sales service for help.	Once every 6 months
Check whether there is any dust around the battery module. Clean the dust if there is any to avoid affecting heat dissipation.	Once every 6 months
Check whether there is any liquid or pest near the battery to avoid intrusion in a long term.	Once every 6 months

## 9 Parameters

### Lynx home F series

Technical Parameters		LX F6.6-H	LX F9.8-H	LX F13.1-H	LX F16.4-H
Usable Energy(kWh)* <sup>1</sup>		6.55	9.83	13.1	16.38
Battery Module		LX F3.3-H: 38.4V 3.27kWh			
Number of Modules		2	3	4	5
Cell Type		LFP(LiFePO4)			
Cell Configuration		64S1P	96S1P	128S1P	160S1P
Nominal Voltage (V)		204.8	307.2	409.6	512
Operating Voltage Range (V)		182.4~230.4	273.6~345.6	364.8~460.8	456~576
Nominal Dis-/Charge Current (A)* <sup>2</sup>		25			
Nominal Power (kW)* <sup>2</sup>		5.12	7.68	10.24	12.8
Operating Temperature (°C)		Charge: 0 ~ +50; Discharge: -20 ~ +50			
Relative Humidity		0~95%			
Max. Operating Altitude (m)		2000			
Communication		CAN			
Weight (kg)		115	158	201	244
Dimensions (W×H×D mm)		600×625×380	600×780×380	600×935×380	600×1090×380
Enclosure Type		IP55			
Installation Location		Grounded			
Standard and Certification	Safety	IEC62619, IEC62040, CEC			
	EMC	CE, RCM			
	Transportation	UN38.3			
*1: Test conditions, 100% DOD, 0.2°C charge & discharge at +25±2 °C for battery system at beginning life. System Usable Energy may vary with different Inverter.					
*2: Nominal Dis-/Charge Current and power derating will occur related to Temperature and SOC.					

**Lynx home F Plus+ series**

Technical Parameters		LX F6.6-H	LX F9.8-H	LX F13.1-H	LX F16.4-H
Usable Energy(kWh)* <sup>1</sup>		6.55	9.83	13.1	16.38
Battery Module		LX F3.3-H: 38.4V 3.27kWh			
Number of Modules		2	3	4	5
Cell Type		LFP(LiFePO4)			
Cell Configuration		64S1P	96S1P	128S1P	160S1P
Nominal Voltage (V)		204.8	307.2	409.6	512
Operating Voltage Range (V)		182.4~230.4	273.6~345.6	364.8~460.8	456~576
Nominal Dis-/Charge Current (A)* <sup>2</sup>		25			
Nominal Power (kW)* <sup>2</sup>		5.12	7.68	10.24	12.8
Short-Circuit Current		2.62kA @ 1.62ms			
Operating Temperature Range (°C)		Charge: 0 ~ +50; Discharge: -20 ~ +50			
Relative Humidity		0~95%			
Max. Operating Altitude (m)		2000			
Communication		CAN			
Weight (kg)		115	158	201	244
Dimensions (W×H×D mm)		600×610×380	600×765×380	600×920×380	600×1075×380
Ingress Protection Rating		IP55			
Storage Temperature (°C)		-20 ~ +45 (≤ One Month); 0 ~ +35 (≤ One Year)			
Mounting Method		Grounded			
Round-trip Efficiency		96.40%			
Cycle Life* <sup>3</sup>		≥3500 @1C/1C			
Standard and Certification	Safety	IEC62619, IEC 62040, VDE2510-50, CEC,CE			
	EMC	CE, RCM			
	Transportation	UN38.3			
*1: Test conditions, 100% DOD, 0.2°C charge & discharge at +25±2 °C for battery system at beginning life. System Usable Energy may vary with different Inverter.					
*2: Nominal Dis-/Charge Current and power derating will occur related to Temperature and SOC.					
*3: Based on 2.5~3.65V voltage rang @25±2°C of Cell under 1C/1C test condition and 80% EOL.					



Official Website



SolarGo App



**ENERGITTEKNIK**  
**www.enertek.se**

**GoodWe Technologies Co.,Ltd.**

 No. 90 Zijin Rd., New District, Suzhou, 215011, China

 [www.goodwe.com](http://www.goodwe.com)

 [service@goodwe.com](mailto:service@goodwe.com)



Contact Information